



ROYAL CANADIAN MOUNTED POLICE

Phone: 780-458-7700

Fax: 780-459-9425

St. Albert Detachment
96 Bellerose Drive
St. Albert, AB T8N 7A4
stalbert.ca

You can access your collision report form at <http://www.ecollision.gov.ab.ca> once statements from ALL parties are received.

Police File Number (given to you on scene by police):

MOTOR VEHICLE COLLISION STATEMENT

Last name: First name: Date of birth:
Address: City:
Postal code: Home phone: Cell phone:
Driver's licence number:

COLLISION INFORMATION

Date: Time:
Exact location (If not at an intersection, provide the nearest crossroad):

YOUR VEHICLE INFORMATION

Make: Model: Year:
Licence plate: Province: Colour:
Your insurance company: Agent:
Policy number: Expiry date:
Did you have a trailer/ other attachment on your vehicle?
If **yes**, what type: Other:
Load details: Did your load spill?
If you are **NOT** the registered owner, complete the information below.
Name: Phone:
Date of birth: Address:

Do you have an independent witness (**NOT** a passenger in your vehicle):

Name:

Phone:

Date of birth:

Address:

OTHER DRIVER & VEHICLE INFORMATION

Driver name:

Phone:

License plate:

Province:

Make:

Model:

Year:

Colour:

Driver insurance company:

Agent:

Policy number:

Expiry date:

Complete the following section if the registered owner was *NOT* the driver:

Name/Business:

Phone:

Address:

Their insurance company:

Agent:

Policy number:

Expiry date:

If not a vehicle, describe animal or other object involved:

DRIVER STATEMENT

In as much detail as possible, describe what happened. Be sure to include the events leading up to the collision and shortly thereafter.

I give consent for the Royal Canadian Mounted Police to release a copy of this statement. This information may be made available to the person/subject of this investigation or their counsel/agent acting on their behalf in any civil, criminal or administrative proceedings.

Signature:

Today's date:

Print name:

COLLISION CIRCUMSTANCES & DAMAGE

Using the check boxes provided on the intersection pictured below, indicate the positions of vehicle or other objects involved in the collision scene. If the collision did not occur at an intersection, do not use this diagram. Instead, provide an image of your own illustration.

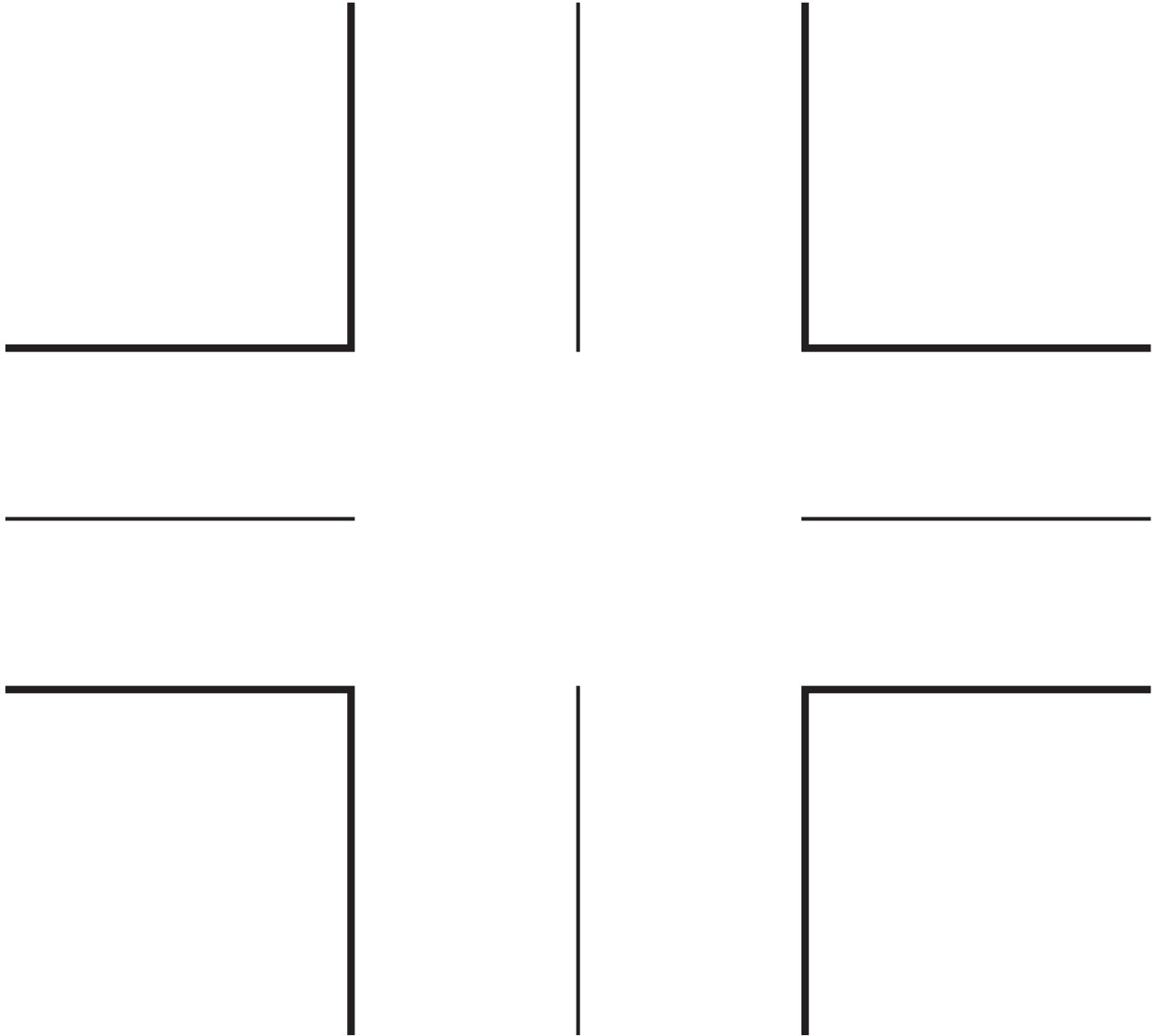

Your direction of travel:

Intersection:

If **YES**, which intersecting or nearest crossing roadway?

COLLISION CIRCUMSTANCES & DAMAGE

Select the boxes that indicate **YOUR** point of impact:

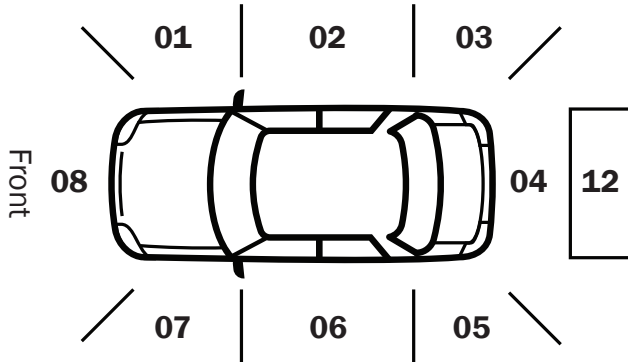

- | | |
|-------------------------|----------------------|
| 09 Unknown | 11 Rollover |
| 10 Undercarriage | 12 Attachment |

Did you obtain an estimate of **YOUR** damages?

Amount: \$

Weather:

Other:

Road conditions:

Other:

Light condition:

Artificial light (street lamps):

Traffic control device:

Traffic control condition:

Other:

Road description:

Location:

Road Class:

Other:

Travel Lane from meridian:

Contributing condition:

Vehicle condition:

Other:

Were you distracted?

Other:

Did a police officer attend the scene:

Is this a hit and run?

COLLISION CIRCUMSTANCES & DAMAGE

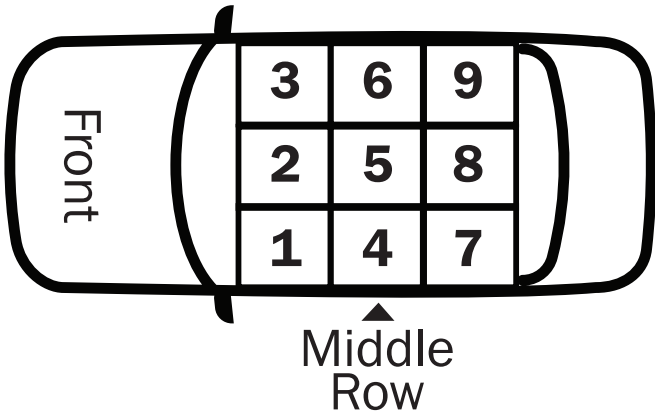

Driver Information

Safety equipment used:

Injury severity:

Number of passengers:

Describe injury treatment sought:

Passenger name:

Gender:

Date of birth:

Address:

Phone number:

Position in vehicle (see legend above):

Safety equipment:

Injury severity:

Describe injury treatment sought:

Passenger name:

Gender:

Date of birth:

Address:

Phone number:

Position in vehicle (see legend above):

Safety equipment:

Injury severity:

Describe injury treatment sought: